

BD Caliper Brake Spring Engaged / Hydraulically Released

In accordance with Nexen's established policy of constant product improvement, the specifications contained in this manual are subject to change without notice. Technical data listed in this manual are based on the latest information available at the time of printing and are also subject to change without notice.

Technical Support: 800-843-7445
(651) 484-5900

www.nexengroup.com



DANGER

Read this manual carefully before installation and operation.

Follow Nexen's instructions and integrate this unit into your system with care.

This unit should be installed, operated and maintained by qualified personnel **ONLY**.

Improper installation can damage your system or cause injury or death.

Comply with all applicable codes.

MEX (55) 53 63 23 31 MTY (81) 83 54 10 18
QRO (442) 1 95 72 60 ventas@industrialmagza.com
INDUSTRIAL
MAGZA
DIST. AUTORIZADO

Nexen Group, Inc.
560 Oak Grove Parkway
Vadnais Heights, Minnesota 55127

ISO 9001 Certified

Copyright 1999 Nexen Group, Inc.

Table of Contents

Installation	4
Friction Facing Clearance Adjustment	6
Maintenance	6
Lubrication	7
Parts Replacement	7
Friction Facing	7
High PV Sleeve Bearings	8
Actuator	9
Replacement Parts	10
Parts List	10
Warranty	12

INSTALLATION

DISC

1. Thoroughly inspect the tapered bore of the disc hub and the tapered surface of the Q.D. bushing. Remove any dirt, grease, or foreign material. Do not use lubricants for this installation.
2. Assemble the Q.D. bushing into the disc hub, aligning the untapped holes in the bushing flange with the tapped holes in the disc hub.
3. Insert the pull-up bolts and alternately and evenly tighten to the recommended torque (See Tables 1 and 2).

NOTE: Runout is minimized if a Dial Indicator is used as the pull-up bolts are tightened. Place the contact tip of the Dial Indicator on the machined surface of the rotor to measure runout. Runout should be .010 - .015 In. [2.5 - 3.8 mm] (See Figure 1).

CAUTION: If excessive tightening torque is applied, bursting pressures are created in the hub. There must be a gap between the flange of the Q.D. bushing and the disc hub to ensure a proper press fit of the Q.D. bushing onto the shaft.

4. To remove the Q.D. bushing, remove the pull-up bolts and reinsert into the threaded holes. Tighten the pull-up bolts to push the disc hub off the Q.D. bushing.

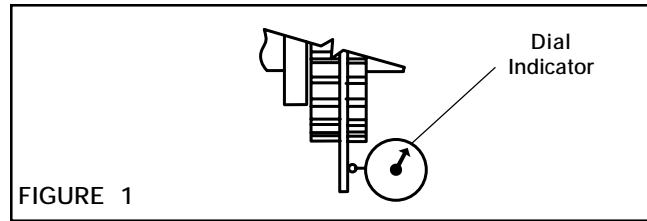

FIGURE 1

TABLE 1
PULL-UP BOLT TORQUES FOR NON-VENTILATED DISCS

RECOMMENDED TIGHTENING TORQUES			
DIA.	PART NO.	QD BUSHING	TORQUE
12"	934201	SF	30 ft-lb [40.5 Nm]
14"	934202	E	60 ft-lb [81 Nm]
16"	932203	E	60 ft-lb [81 Nm]
18"	934204	J	133 ft-lb [182.5 Nm]
20"	934205	J	133 ft-lb [182.5 Nm]
22"	934206	J	133 ft-lb [182.5 Nm]
24"	934207	J	133 ft-lb [182.5 Nm]

TABLE 2
PULL-UP BOLT TORQUES FOR VENTILATED DISCS

RECOMMENDED TIGHTENING TORQUES			
DIA.	PART NO.	QD BUSHING	TORQUE
18.25"	934200	J	135 ft-lb [182.5 Nm]
21"	934300	J	135 ft-lb [182.5 Nm]
24"	934400	J	135 ft-lb [182.5 Nm]

ACTUATOR

NOTE: This BD Caliper Brake is spring engaged and hydraulically disengaged. To release the spring pressure, remove the Vent, then lubricate and insert a Class 8.8 M10-1.5 x 5.5" Threaded Rod into the back of the Actuator; then, using a Flat Washer and Nut, tighten the Nut to release the spring pressure (See Figure 4). A Manual Release Kit (Product No. 933710) containing these items is available from Nexen.

The actuator may be mounted on either side of the brake.

1. Remove the Detent Pins (Item 16) to release the Shoes (Item 3) and the Belleville Disc Springs (Item 29) (See Figure 2).

NOTE: Two Belleville Disc Springs (Item 29) are compressed between the Brake Arm (Item 2) and the Shoe (Item 3). When the Shoe is removed, the Belleville Disc Springs will fall free from the Brake Arms.

2. Remove the Shoes (Item 3) and Belleville Disc Springs (Item 29) (See Figure 2).
3. Remove four Cap Screws (Item 24) (See Figure 2).
4. Remove Pivot Pin Retaining Plate (Item 6) (See Figure 2).

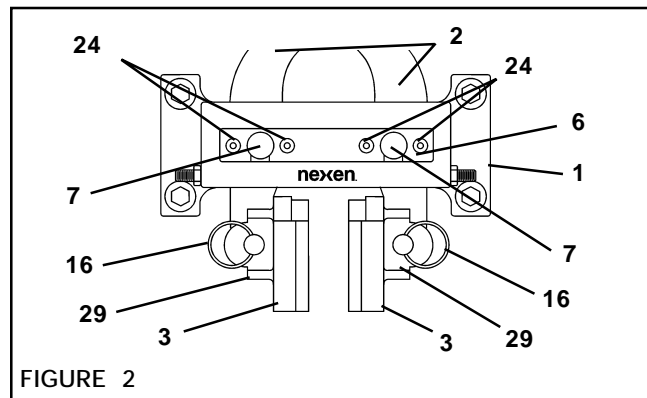

FIGURE 2

5. Press out Pivot Pins (Item 7) (See Figure 2).
6. Slide Brake Arms (Item 2) out of Main Frame (Item 1) (See Figure 2).
7. Position the Brake Arms and Actuator as desired.
8. Slide the Brake Arms (Item 2) back into the Main Frame (Item 1) (See Figure 2).
9. Press in the Pivot Pins (Item 7) (See Figure 2).

10. Reinsert the Pivot Pin Retaining Plate (Item 6) (See Figure 2).
11. Reinstall the four Cap Screws (Item 24) and tighten to 40-50 in-lb [4.5-5.6 Nm] torque.

NOTE: When reinstalling the Shoe (Item 3), first place the Belleville Disc Springs (Item 29) into the recesses provided in the Brake Arm (Item 2). The Belleville Disc Springs should be inserted with their concave side toward the Brake Arm.
12. Reinstall the Shoes (Item 3) and Belleville Disc Springs (Item 29) (See Figure 2).

13. Reinsert the Detent Pins (Item 16) to secure the Shoes (Item 3) and Belleville Disc Springs (Item 29) (See Figure 2).
14. Loosen the Nut to manually reset the brake.
15. Remove the Threaded Rod, Nut, and Washer.
16. Screw the Vent (Item 17) into the back of the Actuator until hand tight and continue to tighten one and one-half turns.

MAIN FRAME

NOTE: Set Screws (Item 27) and Hex. Nuts (Item 28) are provided to hold Brake Arms (Item 2) in place when the BD Caliper Brake is used on vertical shaft installations (See Figure 3).

1. Locate the BD Caliper Brake in the desired position in relation to the disc.

NOTE: This BD Caliper Brake is spring engaged and hydraulically disengaged. To release the spring pressure, remove the Vent, then lubricate and insert a Class 8.8 M10-1.5 x 5.5" Threaded Rod into the back of the Actuator; then, using a Flat Washer and Nut, tighten the Nut to release the spring pressure (See Figure 4). A Manual Release Kit (Product No. 933710) containing these items is available from Nexen.

2. Align the customer supplied support with the Main Frame (Item 1) mounting holes.

NOTE: The support must be capable of sustaining loads produced during braking.

If shims are used under the Main Frame (Item 1) mounting pads, care must be taken to prevent warping of the Main Frame when tightening the customer supplied 5/8"-11 cap screws (See Figure 3).

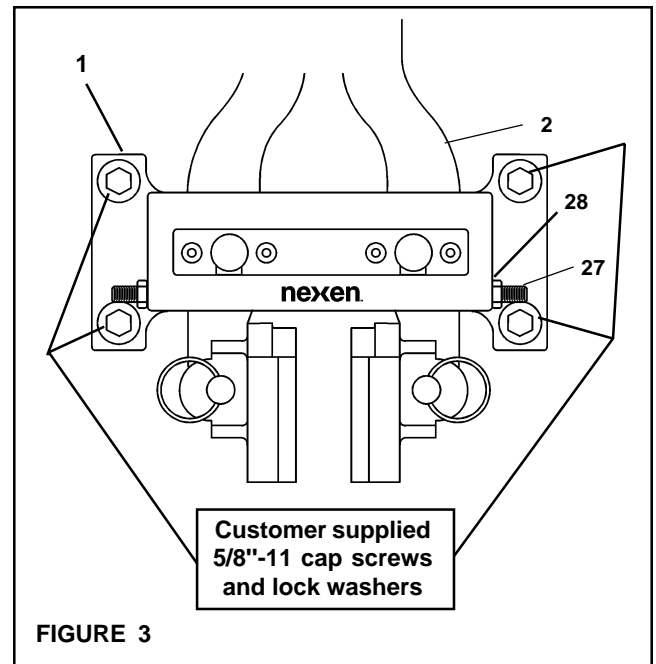

FIGURE 3

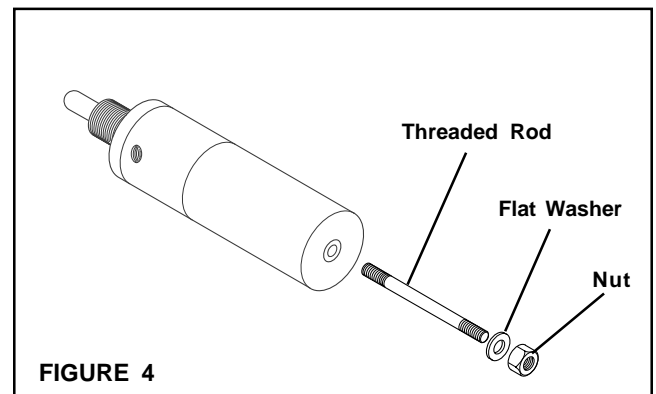

FIGURE 4

WARNING

The customer supplied 5/8"-11 cap screws must sustain the loads produced by the braking preload produced by mounting torque. The torque rating specified above allows a significant load safety factor. **DO NOT OVER TORQUE CAP SCREWS.**

3. Tighten the customer supplied 5/8"-11 cap screws to 150 ft-lb [203.4 Nm] torque.
4. Remove the Threaded Rod, Nut, and Washer.
5. Screw the Vent (Item 17) into the back of the Actuator until hand tight and continue to tighten one and one-half turns.

NOTE: The Vent in the Rear Cylinder prevents debris from entering the Nested Spring stack and relieves any pressure built up by the reciprocating action of the Piston.

FRICION FACING CLEARANCE ADJUSTMENT

1. Remove the Vent (Item 17) from the back of the Actuator.
2. Using the Nexen Manual Release Kit (Product No. 933710), manually release the brake by inserting the Class 8.8 M10 x 1.5 x 5.5" Threaded Rod into the back of the Actuator; then, using the Flat Washer and Nut, tighten the Nut to release the brake (See Figure 5).
3. Loosen the adjustment screw Spanner Nut (Item 12) (See Figure 6).
4. Loosen the Set Screws (Item 27) and the Hex. Nuts (Item 28) on the Main Frame (Item 1) (See Figure 6).
5. Turn the Adjustment Screw (Item 8) out until 1/32" [0.8 mm] spacers can be slid between each of the Friction Facings (Item 4) and the Friction Disc (See Figure 6).
6. Turn the Adjustment Screw (Item 8) in until the spacers can be just pulled out.
7. Tighten the Spanner Nut (Item 12) to 10-15 ft-lb [13.6-20.3 Nm] torque.
8. Adjust the Set Screws (Item 27) until they touch the Brake Arms (Item 2) and tighten the Hex. Nuts (Item 28) on the Main Frame (Item 1).
9. Loosen the Nut to manually reset the brake.
10. Remove the Threaded Rod, Nut, and Washer.
11. Screw the Vent (Item 17) into the back of the Actuator until hand tight and continue to tighten one and one-half turns.

NOTE: The vent in the Rear Cylinder prevents debris from entering the nested spring stack and relieves any pressure built up by the reciprocating action of the Piston.

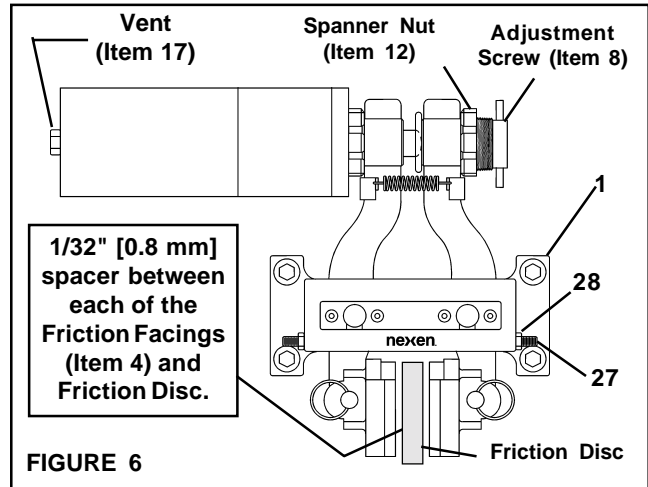
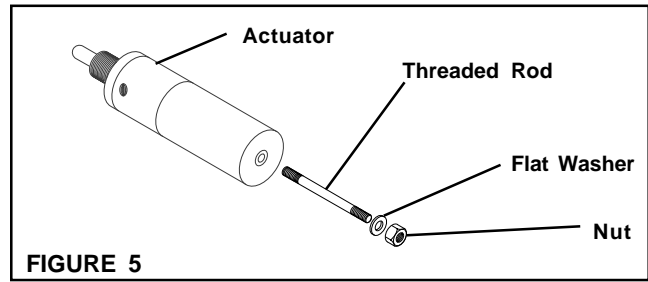

MAINTENANCE

1. Adhere to the following bolt torques (See Table 3).



DANGER

Never use your hand to check the condition of the hydraulic lines. If hydraulic fluid penetrates the skin, get medical help immediately. Failure to get proper medical help may result in loss of limb or life. The safest way to check hydraulic lines for leaks is by holding a piece of cardboard next to the hydraulic line.

2. Check tightness and condition of hydraulic lines. Replace hydraulic lines if signs of deterioration exist.

3. Inspect friction facings for wear. Replace if worn to approximately 5/32" [4 mm] thick.
4. Lubricate items requiring lubrication (See **LUBRICATION**).

TABLE 3

ITEM	DESCRIPTION	TORQUE
24	Cap Screw	40-45 in-lb [4.5-5.1 Nm]
12	Spanner Nut	10-15 ft-lb [13.6-20.3 Nm]
18	Machine Screw	8-12 ft-lb [12-15 Nm]

LUBRICATION

All pivot points on the BD Caliper Brake use self-lubricated high PV Sleeve Bearings.

For tension control applications where the disc is held at elevated temperatures for extended periods, use a light machine oil on Sleeve Bearings (Items 14, 15 and 30) (See Figure 7).

The sliding spherical contact between the Adjustment Screw (Item 8) and the spherical shaft end should be lubricated with a molybdenum disulfide based grease (See Figure 7).

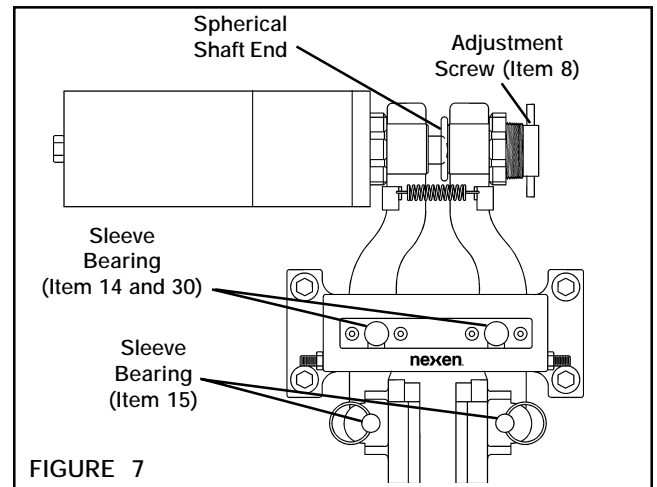

FIGURE 7

PARTS REPLACEMENT

FRICTION FACINGS

NOTE: When replacing Friction Facings, inspect the Friction Disc for scoring or grooves. If necessary, the Friction Disc may be turned. A total of 0.030" [0.762 mm] may be removed from each side of the Friction Disc before it is necessary to replace the Friction Disc.

1. Remove the Vent (Item 17) from the back of the Actuator (See Figure 8).
2. Using the Nexen Manual Release Kit (Product No. 933710) manually release the brake by inserting the Class 8.8 M10 x 1.5 x 5.5" Threaded Rod into the back of the Actuator; then, using a Flat Washer and Nut, tighten the Nut to release the brake (See Figure 9).

NOTE: Two Belleville Disc Springs (Item 29) are compressed between the Brake Arm (Item 2) and the Shoe (Item 3). When the Shoe is removed, the Belleville Disc Springs will fall free from the Brake Arms.

3. Remove Detent Pins (Item 16) to release Friction Facings (Item 4), Shoes (Item 3), and Belleville Disc Springs (Item 29) from Brake Arms (Item 2) (See Figure 8).
4. Remove Friction Facings (Item 4) from the Shoes (Item 3) by removing the old Machine Screws (See Figure 8).
5. Install new Friction Facings (Item 4) using new Machine Screws (Item 18).
6. Tighten the Machine Screws (Item 18) to 8-12 Ft. Lbs. [12-15 N•m] torque.

NOTE: When reinstalling the Shoe (Item 3), first place the Belleville Disc Springs (Item 29) into the recesses provided in the Brake Arm (Item 2). The Belleville Disc Springs should be inserted with their concave side toward the Brake Arm.

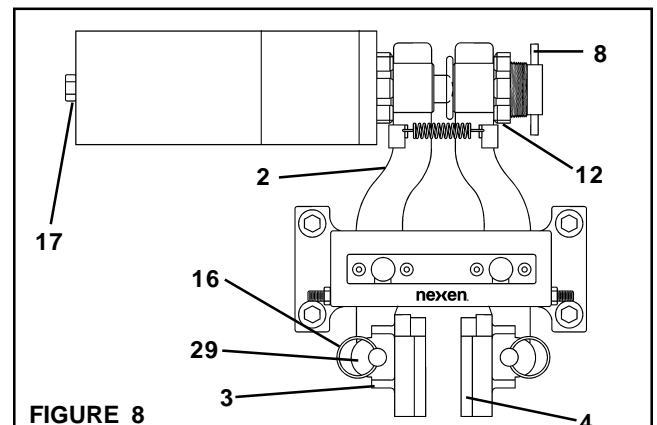

FIGURE 8

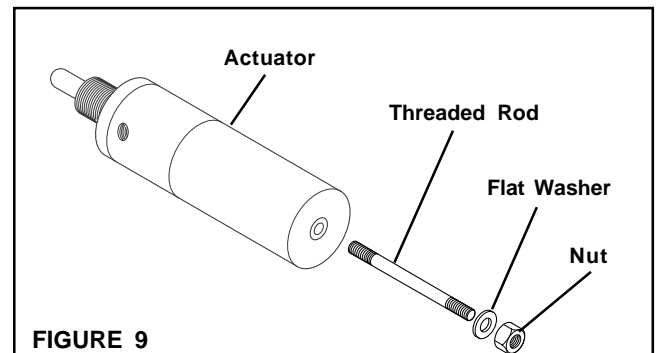

FIGURE 9

7. Loosen adjustment screw Spanner Nut (Item 12) and back out Adjustment Screw (Item 8) until the Friction Facings, Shoes, and Belleville Disc Springs will slide back onto the Brake Arms (Item 2) (See Figure 8).
8. Replace the Detent Pins (Item 16) (See Figure 8).
9. Perform Friction Facing adjustment (See **FRICTION FACING CLEARANCE ADJUSTMENT**).

HIGH PV SLEEVE BEARINGS

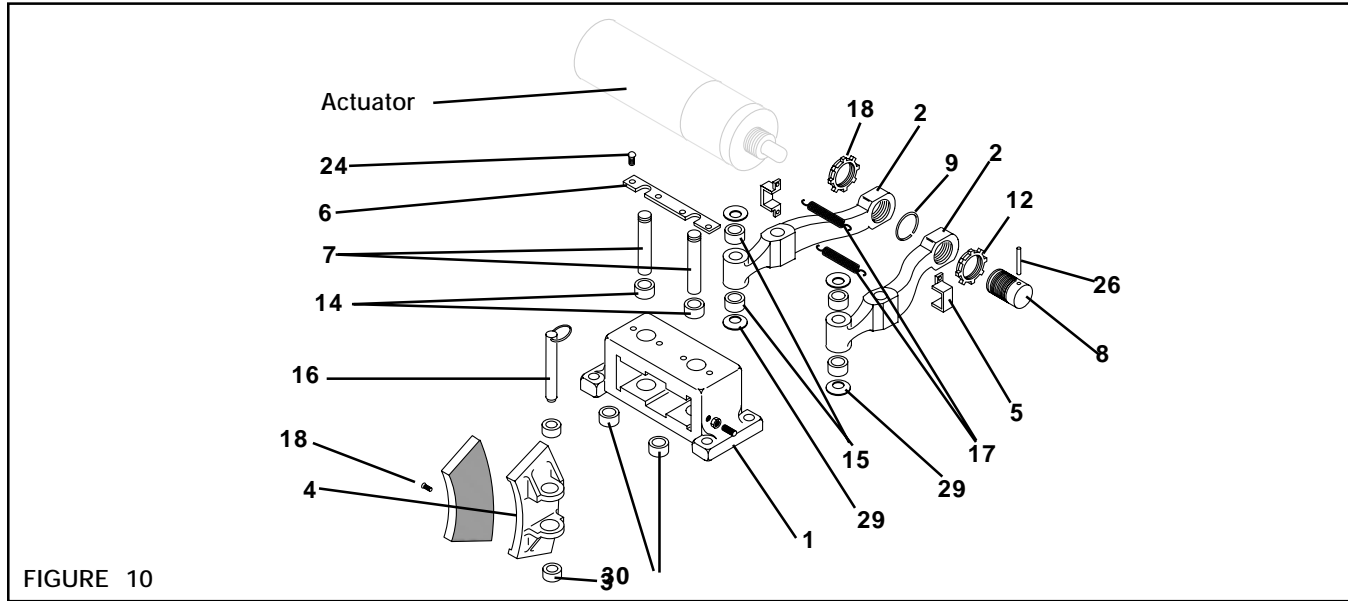

FIGURE 10

NOTE: This BD Caliper Brake is spring engaged and hydraulically disengaged. To release the spring pressure, remove the Vent, then lubricate and insert a Class 8.8M10 x 1.5 x 5.5" Threaded Rod into the back of the Actuator; then, using a Flat Washer and Nut, tighten the Nut to release the spring pressure (See Figure 4). A Manual Release Kit (Product No. 933710) containing these items is available from Nexen.

NOTE: Tops of Sleeve Bearings (Item 14) must be flush with top of Main Frame (Item 1) and bottoms of Sleeve Bearings (Item 30) must be flush with bottom of Main Frame (Item 1).

1. Loosen the Spanner Nut (Item 12) (See Figure 10).
 2. Remove the Actuator from the Brake Arm (Item 2) (See Figure 10).
 3. Remove the Extension Springs (Item 17) and Spring Clips (Item 5) from the Brake Arms (Item 2) (See Figure 10).
 4. Remove the Detent Pins (Item 16) from the Brake Arms (Item 2), Friction Facings (Item 4), Shoes (Item 3), and Belleville Disc Springs (Item 29) (See Figure 10).
- NOTE:** Two Belleville Disc Springs (Item 29) are compressed between the Brake Arm (Item 2) and the Shoe (Item 3). When the Shoe is removed, the Belleville Disc Springs will fall free from the Brake Arms.
5. Slide the Friction Facings (Item 4) and Shoes (Item 3) off of the Brake Arms (Item 2) (See Figure 10).
 6. Remove the four Cap Screws (Item 24) securing the Pivot Pin Retaining Plate (Item 6) (See Figure 10).
 7. Remove the Pivot Pin Retaining Plate (Item 6) (See Figure 10).
 8. Press the Pivot Pins (Item 7) out of the BD Caliper Brake (See Figure 10).
 9. Slide the Brake Arms (Item 2) out of the Main Frame (Item 1) (See Figure 10).
 10. Press the old Sleeve Bearings (Items 14 and 30) out of the Main Frame (Item 1) (See Figure 10).
 11. Press new Sleeve Bearings (Items 14 and 30) into the Main Frame (Item 1) (See Figure 10).

12. Press the old Sleeve Bearings (Item 15) out of the Shoes (Item 3) (See Figure 10).

NOTE: Sleeve Bearings (Item 15) must be pressed from both sides to be flush with the recess in the Brake Arm.

13. Press new Sleeve Bearings (Item 15) into the Brake Arm (Item 2) (See Figure 10).
14. Slide the Brake Arms (Item 2) back into the Main Frame (Item 1) (See Figure 10).

NOTE: There is one threaded hole on each side of the front of the Main Frame (Item 1). The BD Arms (Item 2) must be inserted into the Main Frame from the opposite end. (See Figure 10)

15. Install the Pivot Pins (Item 7) (See Figure 10).
16. Install the Pivot Pin Retaining Plate (Item 6) (See Figure 10).
17. Install the four Cap Screws (Item 24) to secure the Pivot Pin Retaining Plate (Item 6) (See Figure 10).
18. Tighten Cap Screws (Item 24) to 40-50 in-lb [4.5-5.6 Nm].

NOTE: Two Belleville Disc Springs (Item 29) are compressed between Brake Arm (Item 2) and Shoe (Item 3). When Shoe is removed, Belleville Disc Springs will fall free from Brake Arms.

19. Slide the Friction Facings (Item 4) and Shoes (Item 3) over the Belleville Disc Springs (Item 29) and onto the Brake Arms (Item 2); then, install the Detent Pins (Item 16) (See Figure 10).
20. Install the Spring Clips (Item 5) and Extension Springs (Item 17) onto the Brake Arms (Item 2) (See Figure 10).
21. Screw the Actuator back onto the Brake Arm (Item 2) as far as possible (See Figure 10).
22. Loosely attach the Spanner Nut (Item 12).
23. Perform Friction Facing adjustment (See **FRICITION FACING CLEARANCE ADJUSTMENT**).

MEX (55) 53 63 23 31 MTY (81) 83 54 10 18
 QRO (442) 1 95 72 60 ventas@industrialmagza.com
INDUSTRIAL MAGAZA
 DIST. AUTORIZADO

ACTUATOR

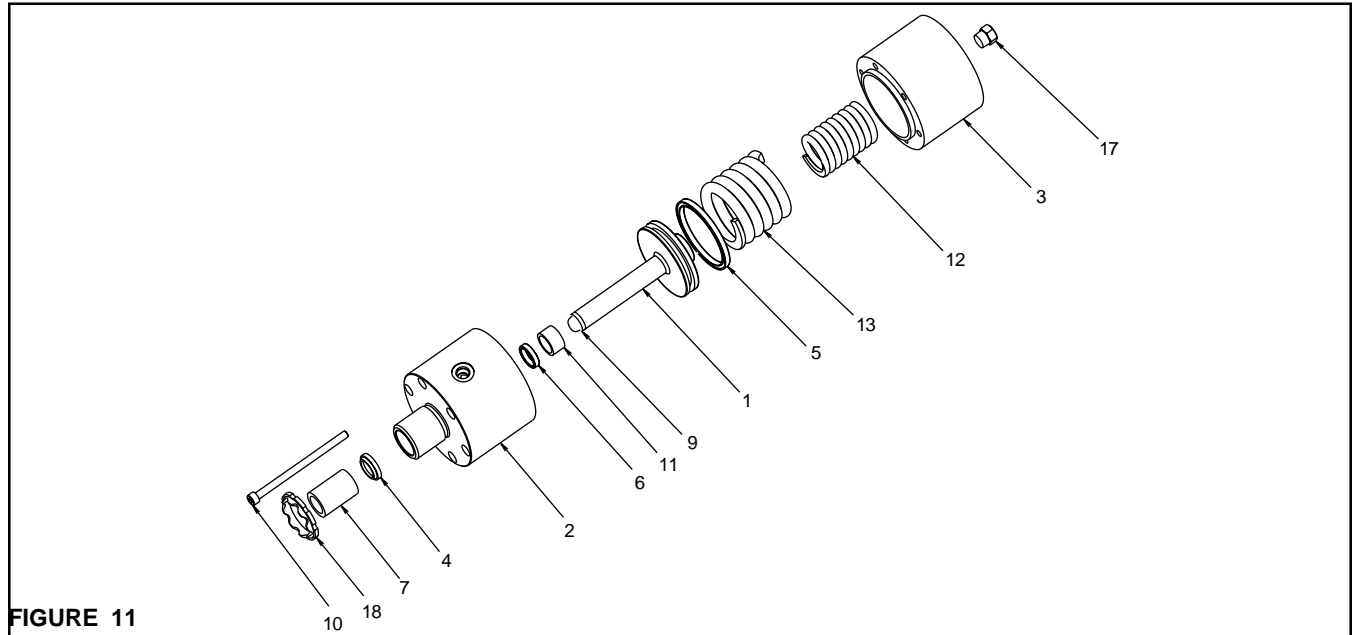

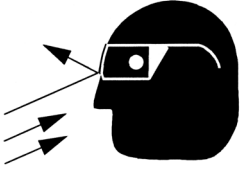

FIGURE 11

1. Disengage the hydraulic supply from the Actuator and plug the hydraulic ports in the Actuator.

 WARNING	
<p>The Actuator is spring loaded.</p> <p>Always wear safety goggles when working with spring loaded devices.</p>	

NOTE: This BD Caliper Brake is spring engaged and hydraulically disengaged. To release the spring pressure, remove the Vent, then lubricate and insert a Class 8.8 M10 x 1.5 x 5.5" Threaded Rod into the back of the Actuator; then, using a Flat Washer and Nut, tighten the Nut to release the spring pressure (See Figure 12). A Manual Release Kit (Product No. 933710) containing these items is available from Nexen.

2200 lb [9786 N] of force is required to compress the springs.

2. Loosen the Spanner Nut (Item 18) locking the Actuator to the BD Caliper Brake and remove the Actuator.
3. Slowly release the pressure on the actuator by unscrewing the Nut in the Threaded Rod.
4. Remove the six Socket Head Cap Screws (Item 10).
5. Separate the Rear Cylinder (Item 3) from the Front Cylinder (Item 2).
6. Push the Piston (Item 1) out of the Front Cylinder (Item 2).

NOTE: Be careful not to scratch the Piston (Item 1) when removing or installing the Retaining Ring (Item 11).

NOTE: The Piston Seal is coated with a special compound. Avoid excessive handling of the Piston Seal.

7. Remove the Piston Seal (Item 5) from Piston (Item 1) and install a new seal.
8. Remove both Sleeve Bearings (Items 7 & 11). Special tool may be required for removal.

NOTE: The Rod Seal (Item 6) is coated with a special compound. Avoid excessive handling of the Rod Seal.

While removing the Rod and Wiper Seals, note the orientation of the seals to assure proper installation of the new seals.

9. Remove and replace both the Wiper Seal (Item 4) and the Rod Seal (Item 6) with new seals.
10. Press new Sleeve Bearing (Item 11) into the Front Cylinder (Item 2). This bearing must be pressed in 0.100 in. (2.54 mm) from the face of the Front cylinder (Item 2). (See Figure 11).
11. Press a new Sleeve Bearing (Item 7) into the Front Cylinder (Item 2). This bearing must be flush with the end of the Front Cylinder (Item 2). (See Figure 11).
12. Push the Piston (Item 1) into the Front Cylinder (Item 2). Be careful not to damage the Piston Seal (Item 5) during assembly. A light film of oil around the seal may help during installation.
13. Put both the Inner Spring (Item 12) and the Outer Springs (Item 13) into the Rear Cylinder (Item 3).
14. Align the bolt holes of the Front and Rear Cylinders (Items 2 & 3) together. Assure that the Inner and Outer Springs (Items 12 & 13) are not making contact with each other.
15. Apply a drop of Loctite® 242 to the six Socket Head Cap Screws and thread them into the Rear Cylinder (Item 3).

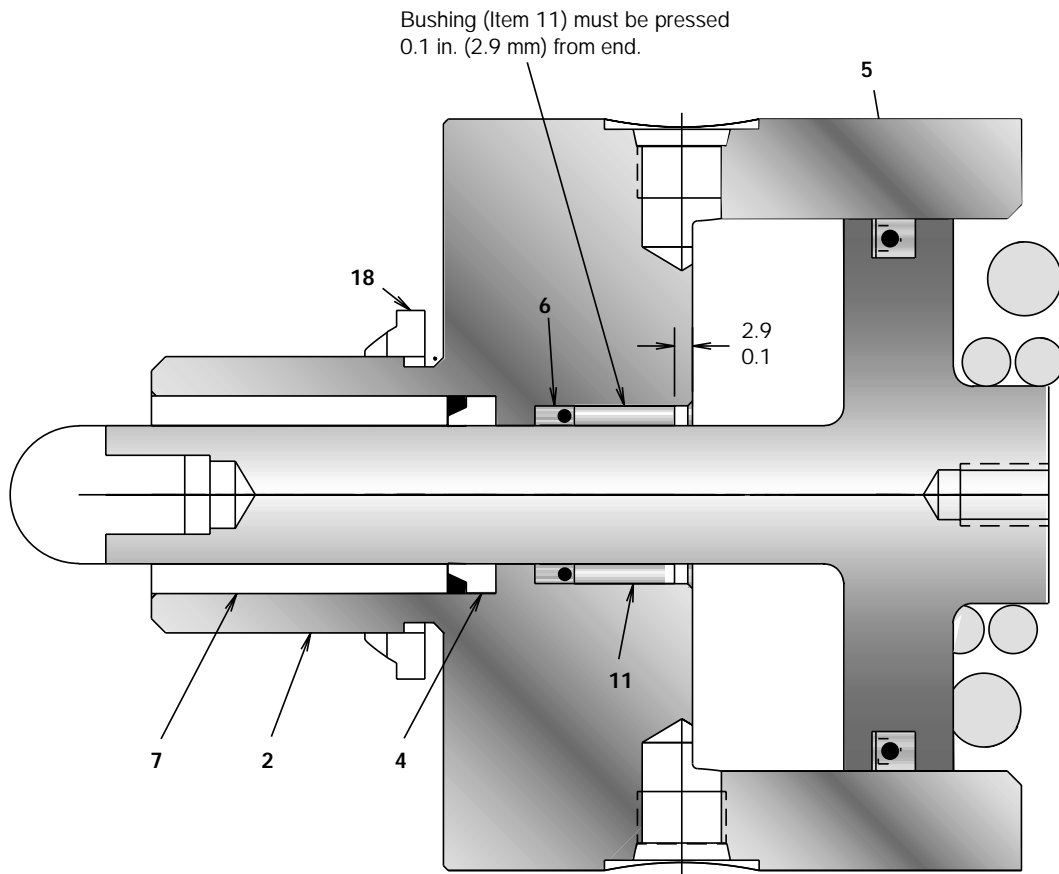

FIGURE 12

REPLACEMENT PARTS

The item or balloon number for all Nexen products is used for part identification on all product parts lists, product price lists, unit assembly drawings, bills of materials, and instruction manuals.

When ordering replacement parts, specify model designation, item number, part description, and quantity. Purchase replacement parts through your local Nexen Distributor.

PARTS LIST

MANUAL RELEASE KIT (Product No. 933710)

ITEM	DESCRIPTION	QTY
1	Class 8.8 M10 x 1.5 x 5.5 Threaded Rod	1
2	M10 - 1.25" Nut	1
3	M10 Flat Washer	1

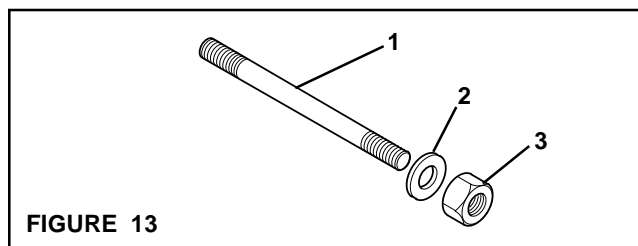

FIGURE 13

MAIN FRAME

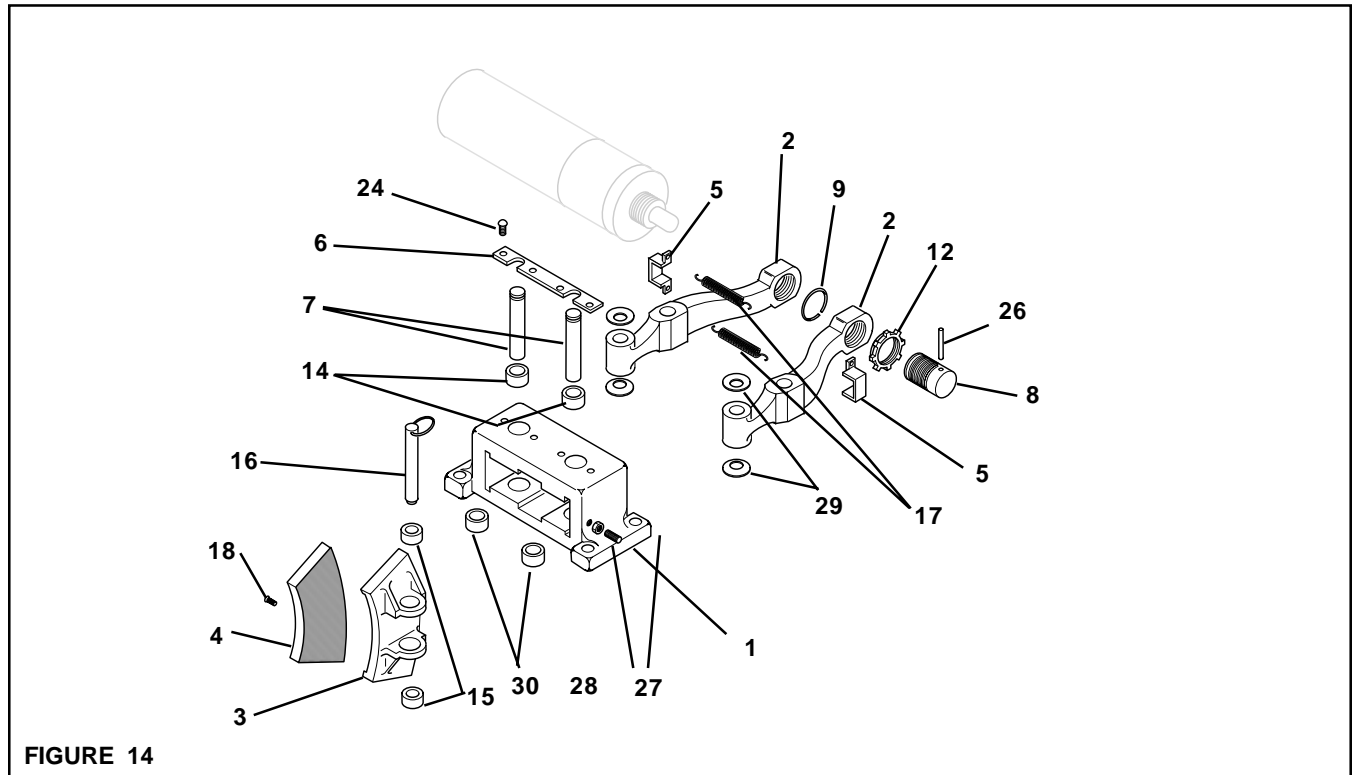

FIGURE 14

ITEM	DESCRIPTION	QTY
1	Main Frame	1
2	Brake Arm	2
3	Shoe	2
4 ²	Friction Facing	2
5	Spring Clip	2
6	Pivot Pin Retaining Plate	1
7	Pivot Pin (Arm)	2
8	Adjustment Screw	1
9	Adjustment Screw Retaining Ring	1
12	Spanner Nut	1

ITEM	DESCRIPTION	QTY
14 ¹	Sleeve Bearing	2
15 ¹	Sleeve Bearing	4
16	Detent Pin	2
17 ¹	Extension Spring	2
18 ²	Machine Screw	8
24	Cap Screw	4
26	Grooved Pin	1
27	Set Screw	2
28	Hex. Nut	2
29 ²	Belleville Disc Spring	4
30 ¹	Sleeve Bearing	2

¹ Denotes Repair Kit items.
 Repair Kit Product No. 933598.
 Friction Facing Kit Product No. 933599.

² Denotes Facing Kit items.
 Friction Facing Kit Product No. 933599.

WARRANTY

Warranties

Nexen warrants that the Products will be free from any defects in material or workmanship for a period of 12 months from the date of shipment. NEXEN MAKES NO OTHER WARRANTY, EXPRESS OR IMPLIED, AND ALL IMPLIED WARRANTIES, INCLUDING WITHOUT LIMITATION, IMPLIED WARRANTIES OF MERCHANTABILITY AND FITNESS FOR A PARTICULAR PURPOSE ARE HEREBY DISCLAIMED. This warranty applies only if (a) the Product has been installed, used and maintained in accordance with any applicable Nexen installation or maintenance manual for the Product; (b) the alleged defect is not attributable to normal wear and tear; (c) the Product has not been altered, misused or used for purposes other than those for which it was intended; and (d) Buyer has given written notice of the alleged defect to Nexen, and delivered the allegedly defective Product to Nexen, within one year of the date of shipment.

Exclusive Remedy

The exclusive remedy of the Buyer for any breach of the warranties set out above will be, at the sole discretion of Nexen, a repair or replacement with new, serviceably used or reconditioned Product, or issuance of credit in the amount of the purchase price paid to Nexen by the Buyer for the Products.

Limitation of Nexen's Liability

TO THE EXTENT PERMITTED BY LAW NEXEN SHALL HAVE NO LIABILITY TO BUYER OR ANY OTHER PERSON FOR INCIDENTAL DAMAGES, SPECIAL DAMAGES, CONSEQUENTIAL DAMAGES OR OTHER DAMAGES OF ANY KIND OR NATURE WHATSOEVER, WHETHER ARISING OUT OF BREACH OF WARRANTY OR OTHER BREACH OF CONTRACT, NEGLIGENCE OR OTHER TORT, OR OTHERWISE, EVEN IF NEXEN SHALL HAVE BEEN ADVISED OF THE POSSIBILITY OR LIKELIHOOD OF SUCH POTENTIAL LOSS OR DAMAGE. For all of the purposes hereof, the term "consequential damages" shall include lost profits, penalties, delay damages, liquidated damages or other damages and liabilities which Buyer shall be obligated to pay or which Buyer may incur based upon, related to or arising out of its contracts with its customers or other third parties. In no event shall Nexen be liable for any amount of damages in excess of amounts paid by Buyer for Products or services as to which a breach of contract has been determined to exist. The parties expressly agree that the price for the Products and the services was determined in consideration of the limitation on damages set forth herein and such limitation has been specifically bargained for and constitutes an agreed allocation of risk which shall survive the determination of any court of competent jurisdiction that any remedy herein fails of its essential purpose.

Limitation of Damages

In no event shall Nexen be liable for any consequential, indirect, incidental, or special damages of any nature whatsoever, including without limitation, lost profits arising from the sale or use of the Products.

Warranty Claim Procedures

To make a claim under this warranty, the claimant must give written notice of the alleged defect to whom the Product was purchased from and deliver the Product to same within one year of the date on which the alleged defect first became apparent.

MEX (55) 53 63 23 31
QRO (442) 1 95 72 60
MTY (81) 83 54 10 18
ventas@industrialmagza.com



nexen[®]

Nexen Group, Inc.
560 Oak Grove Parkway
Vadnais Heights, MN 55127

800.843.7445
Fax: 651.286.1099
www.nexengroup.com

ISO 9001 Certified